

PLANO 50

Hinweise zur Türblattfertigung

0339

02

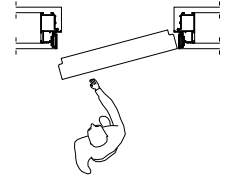
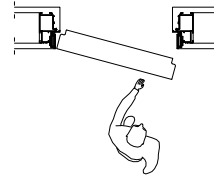
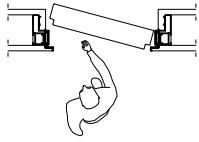
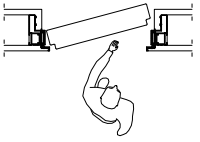

Ausführung "Drücken" mit Sturz

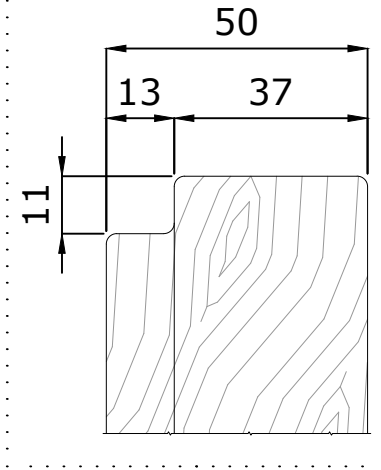
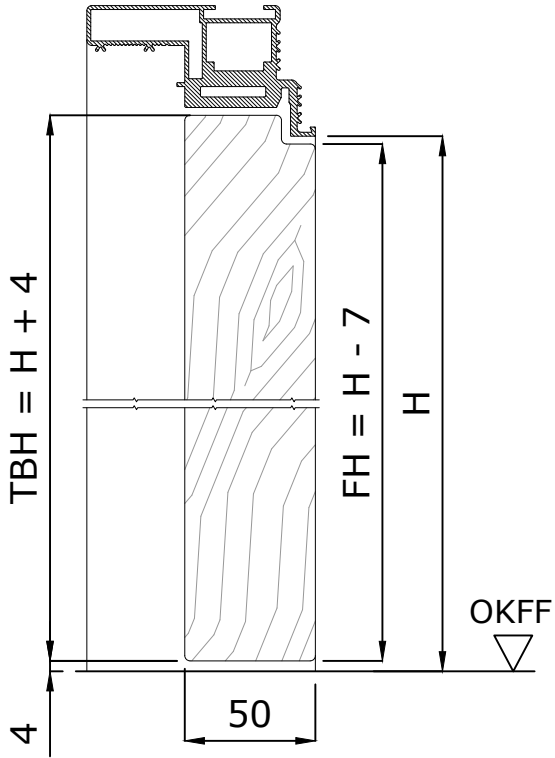

Ausführung "Ziehen" mit Sturz

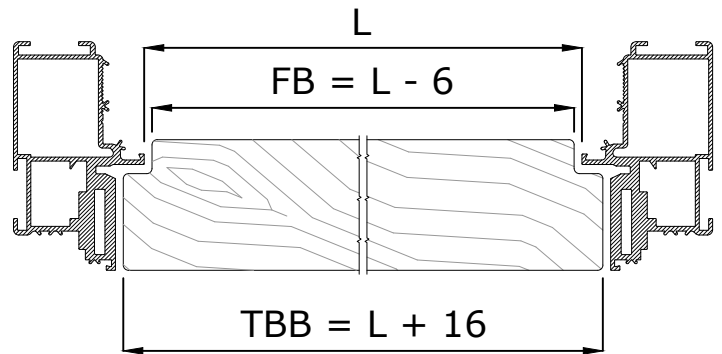
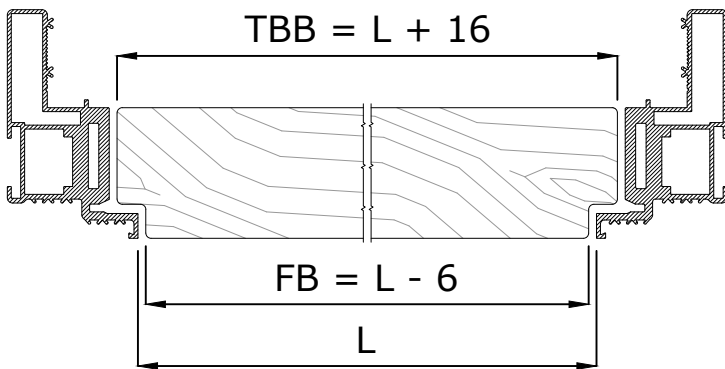
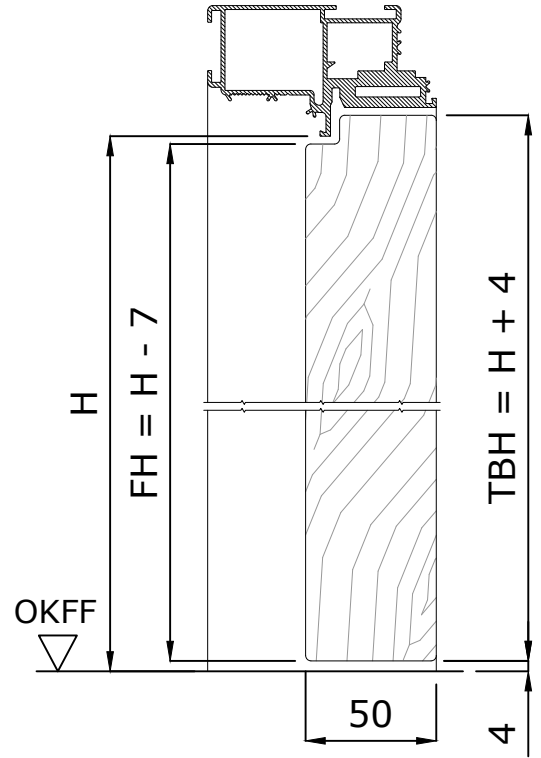

Ausführung ohne Sturz

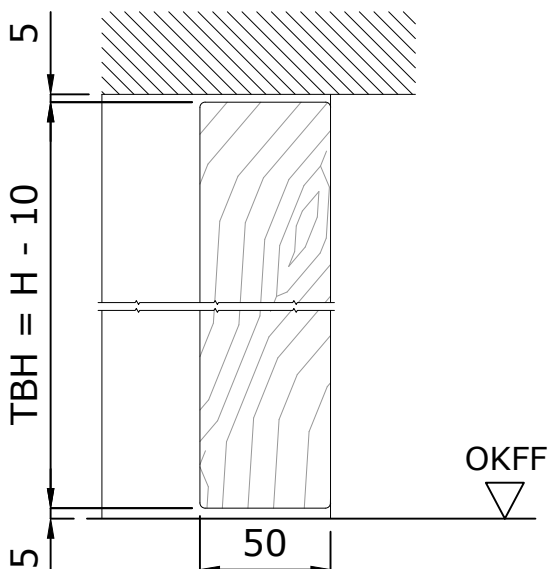

Legende

- TBB = Türblattbreite
- TBH = Türblatthöhe
- H = Lichte Höhe
- FH = Falzhöhe
- FB = Falzbreite
- L = Lichte Breite
- OKFF = Oberkante fertiger Fußboden



VORSPRUNG DURCH WEITSICHT

www.eclisse.de

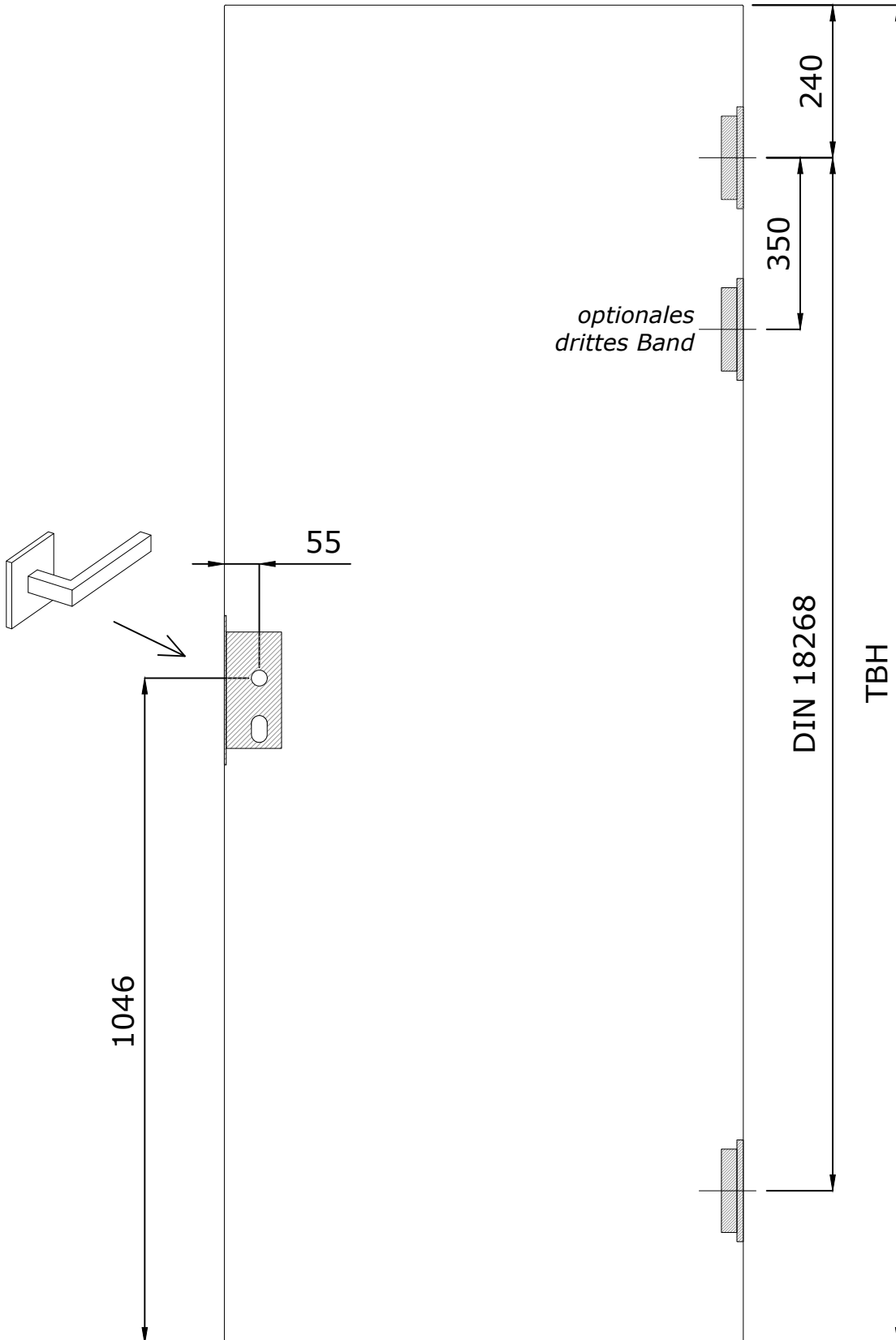
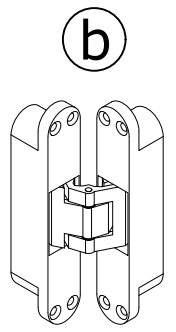
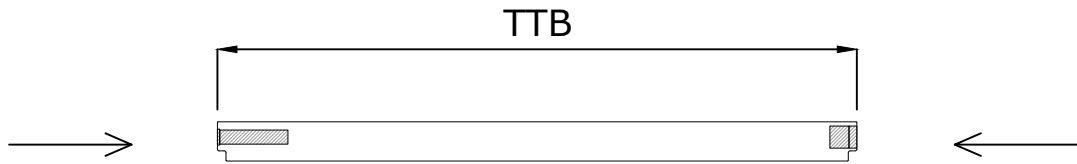
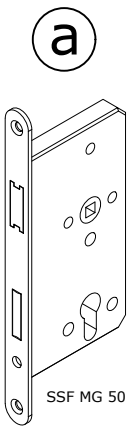

Es werden zwei verdeckt liegende Bänder bis zu einer Türbreite von 901 mm, und drei Bänder ab einer Breite von 902 mm gesetzt.

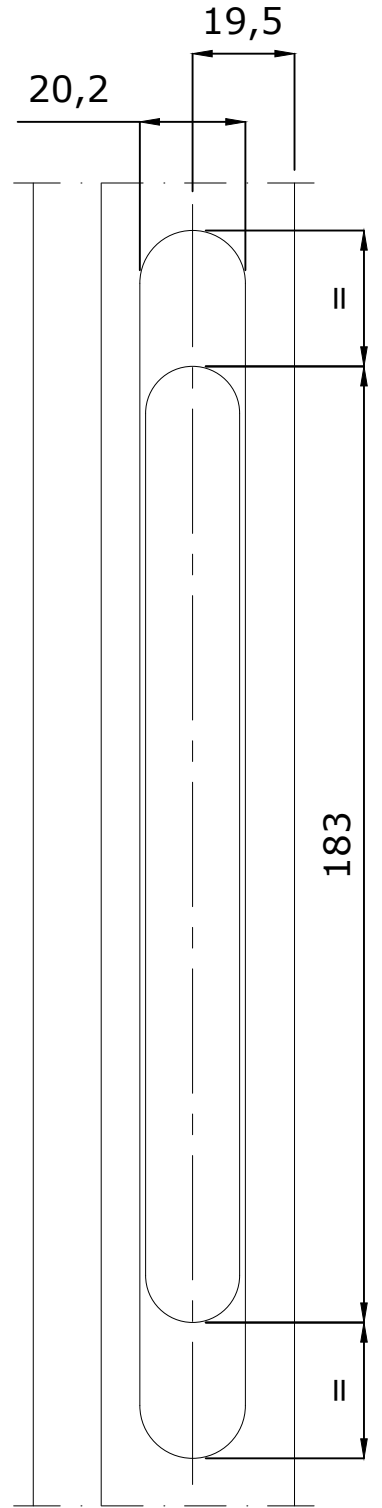
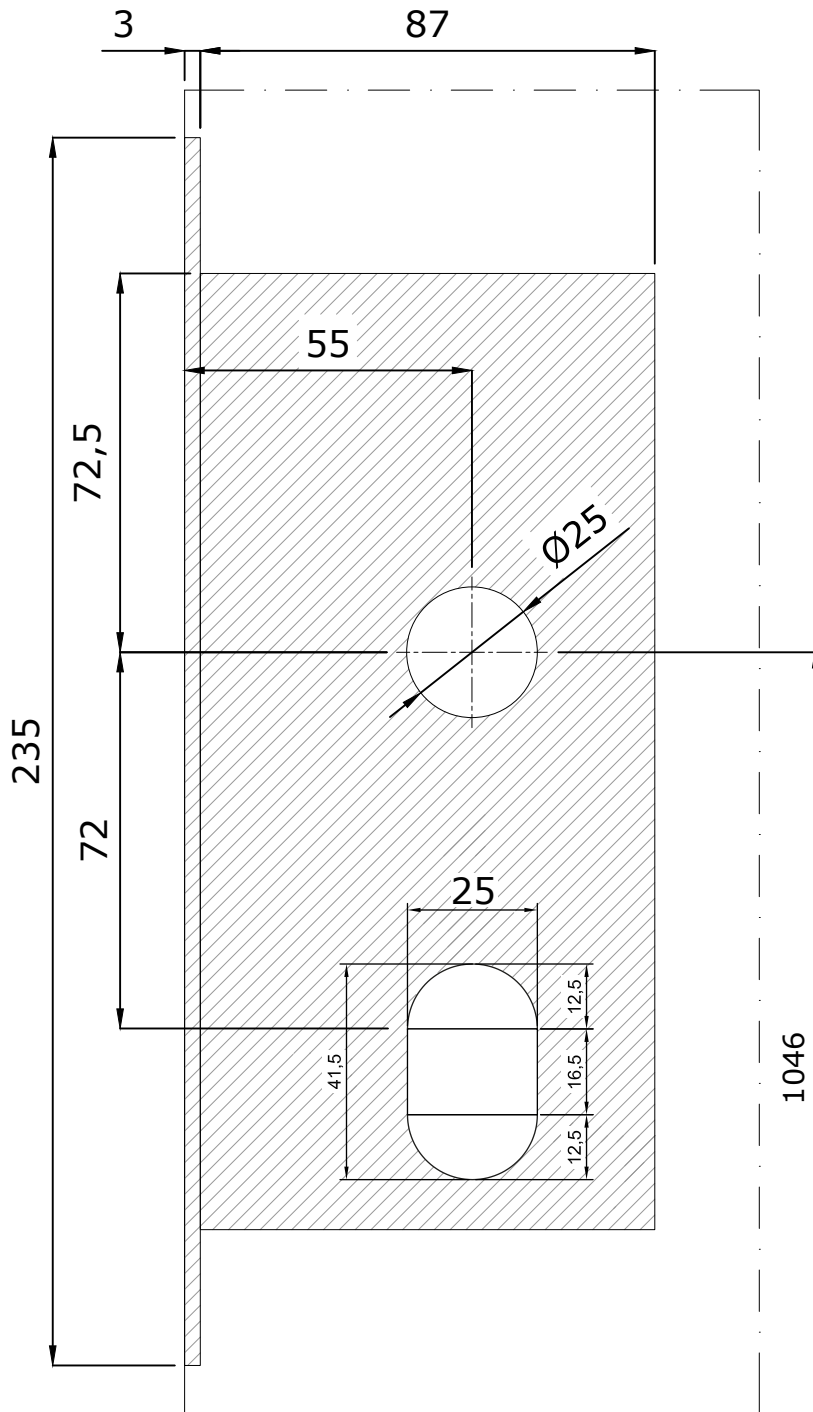
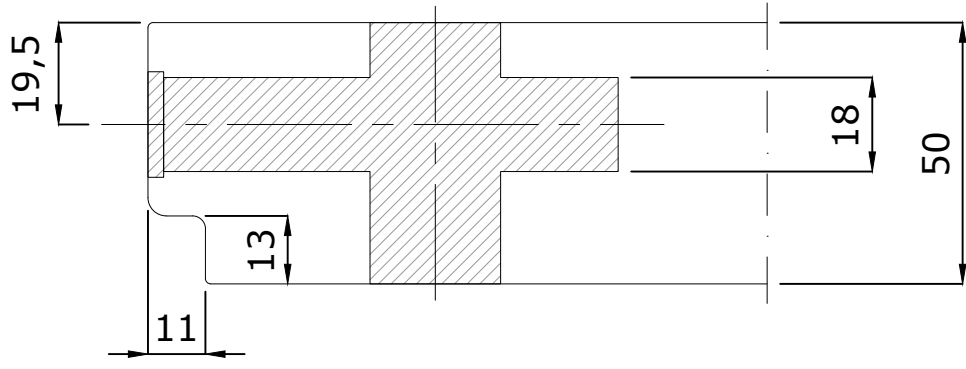
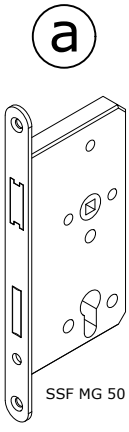

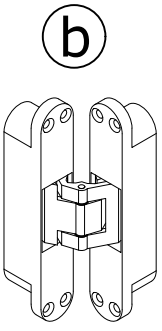

b

